

### Water Flow Indicator with Retard

#### Technical Features

- Connection:** AWWA C606
- Sizes:** 2" , 2 1/2" , 3" , 4" , 5" , 6" , 8" , 10"
- Working Pressure:** 300 PSI
- Working Temperature Range:** 0C°-80C°(32°F-176°F)
- Coating Details:** Fusion Bonded Epoxy Coating in accordance with ANSI/AWWA C550
- Electical Ratings:** 125/250VAC 5A 24/30VDC 3A
- Minimum Flow Rate For Alarm:** 4-10 gpm
- Approval:** UL

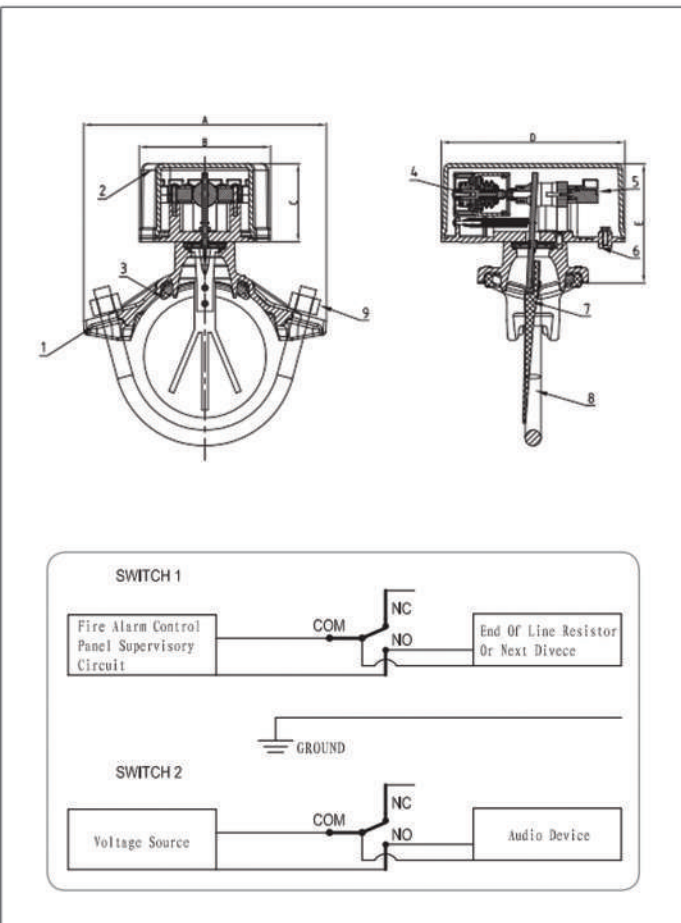

#### Valve Material List

NO	Description	Material
1	Body	ASTM A5366,65-45-12
2	Cover	Aluminum Alloy
3	Gasket	EPDM
4	Delay Device	Plastic
5	Signal Connection	N/A
6	Connection Plate	Aluminum Alloy
7	Vane	Plastic
8	U-Bolts	Carbon Steel Zinc Plated
9	Nuts	Carbon Steel Zinc Plated

#### Dimensions

Size	mm	R	A	B	C	D	E	Hole Dia.
2"	50	60.3	116	100	59.5	140	79.5	29
2.5"	65	73	120	100	59.5	140	79.5	29
2.5"	65	76.1	120	100	59.5	140	79.5	29
3"	80	88.9	145	100	59.5	140	80.9	51
4"	100	114.3	185	100	59.5	140	98.5	51
5"	125	139.7	212	100	59.5	140	82.6	51
5"	125	141.3	212	100	59.5	140	82.6	51
6"	150	165.1	254	100	59.5	140	90.4	51
6"	150	168.3	254	100	59.5	140	90.4	51
8"	200	219.1	298	100	59.5	140	90.5	51
10"	250	273	381	100	59.5	140	100.5	70